

# TIV

## TECHNICAL GUIDANCE

# SWIRLMAX

## VFM4200

### Vortex Flowmeter

### OUTLINE

**SWIRLMAX** is a 2-wire, all-in-one type vortex flowmeter with temperature and pressure sensors.

The VFM4200 can easily correct flow measurements of steam and gases for temperature and pressure. There is no need for additional sensors and correctors.

The VFM4200 is ideal for managing the energy of steam and gases.

### FEATURES

- ❑ Measuring various fluids  
Steam, gases, and liquids
- ❑ Flow correction for saturated steam by temperature as standard  
The VFM4200 contains a temperature sensor and stores a table of saturated steam density in the amplifier.  
The flowmeter measures the flow rate of saturated steam, corrects it by temperature, and outputs the result. It is easy to measure the mass flow rate of saturated steam.
- ❑ Optional pressure sensor  
A pressure sensor can be mounted as an option. The VFM4200 can easily correct flow measurements of steam and gases by temperature and pressure. There is no need for additional sensors and correctors.
- ❑ Corrosion-resistant all-stainless-steel construction  
All wetted parts are made of welded stainless steel and are robust, with excellent corrosion and heat resistance.
- ❑ Reduced diameters available for flange type  
Flange type flowmeters with reduced meter sizes are available for measuring low flow rates.  
The diameter can be reduced by up to two steps from the connection size.
- ❑ Advanced vortex frequency detection (AVFD) ensures stable reading  
The original AVFD technology eliminates external disturbances and ensures stable, reliable readings.
- ❑ Robust construction  
Robust, maintenance-free construction with no moving parts



### OPERATING PRINCIPLE

An object in a flow generates alternating vortices (Karman vortices) on both sides of the object in the downstream, and the frequency of the vortices is proportional to the flow velocity.

The VFM4200 measures this frequency with a piezoelectric element in the vortex detector, converts it into flow rate signals, and outputs them. The vortex detector is equipped with a temperature sensor (Pt1000 RTD), which measures fluid temperature and corrects the flow rate of saturated steam by temperature.

With an optional pressure sensor mounted, the flowmeter can correct the flow rate of gases and superheated steam by temperature and pressure.

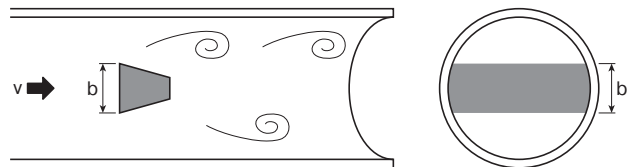

$$f = (S \times v) / b$$

f : Vortex frequency  
v : Flow velocity  
S : Constant of proportion (Strouhal number)  
b : Width of bluff body

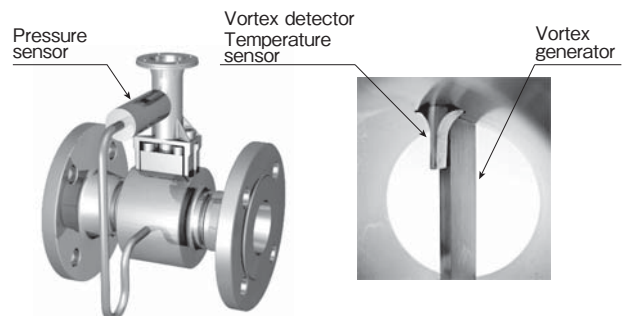

## STANDARD SPECIFICATIONS

### General Specifications

- Meter size
  - Flange type : 15, 25, 40, 50, 80, 100, 150, 200, 250, and 300 mm
  - Wafer type : 15, 25, 40, 50, 80, and 100 mm
- Protection class : IP66/67 (IEC 60529)
- Ambient temperature : -40 to +85°C
  - \* Refer to “Explosionproof Specifications” for explosionproof products.

### Fluid Specifications

- Measured fluid : Gas, steam, and liquid
- Temperature : -40 to +240°C
  - \* Refer to “Explosionproof Specifications” for explosion proof products.
- Pressure : Up to flange rating (max. 10 MPa)
- Viscosity : Up to 10 mPa·s
- Reynolds number (Re) : 10,000 or higher

### Sensor Specifications

- Wetted parts material : Stainless steel (316L)
  - [Metering tube, flange, vortex detector, and gasket for vortex detector]
- Process connection : Flange or wafer (inserted between pipe flanges)
- Flange : JIS10K/20K
  - ASME class 150/300/600
- Temperature sensor : Built-in Pt1000 RTD (standard)
- Pressure sensor : Pressure sensor integrated (optional)
- Connection box material: Aluminum alloy (For remote type)
- Connection cable length: Max. 50 m (For remote type)

### Converter Specifications

- Housing material : Aluminum alloy
  - Painting : Two-layer coating (Epoxy / Polyester)
  - Color : Gray (converter housing)  
Jade green (converter cover)
  - Cable entry : G1/2 female, 1/2 NPT female, or M20 watertight gland
  - Power supply : 24 V DC (12 to 36 V DC)
    - \* Refer to “Explosionproof Specifications” for explosionproof products.
  - Display : LCD
    - 2 screens can be alternated, up to 3 lines on each screen
    - Selectable among flow rate, total flow, temperature, flow velocity, vortex frequency, and pressure (optional)
  - Output
    - Current output
      - Output : 2-wire, 4-20 mA DC
      - Allowable load resistance :  $R=(E-12) / 0.022\Omega$  (E=Power voltage (V))
    - Contact output
      - Output : Selectable among pulse output, frequency output, status output, and limit switch
      - Output type : Open collector (normally closed) or NAMUR output
      - Pulse rate : Max. 1,000 Hz (pulse output and frequency output)
      - Pulse width : 0.5 to 2,000 ms
      - Load rating : Max. 36 V DC, 100 mA (open collector output)
- \* Refer to “Explosionproof Specifications” for explosionproof products.

- Flow rate correction function
  - : Flow correction of saturated steam by temperature (standard)
  - Flow correction of superheated steam and gas by temperature and pressure (optional)
- HART communication : HART7 (standard)
- Damping time constant (63% response) : 0 to 100 s (variable)
- Test function : Simulated current output and contact output
- Burnout : Either 22 mA or 3.55 mA can be output at error

### Accuracy (under standard conditions)

- $Re \geq 20,000$  :  $\pm 0.75\%$  of reading (liquid)  
 $\pm 1\%$  of reading (gas and steam)
  - $10,000 < Re < 20,000$  :  $\pm 2\%$  of reading (liquid, gas, and steam)
- [When corrected by temperature and pressure]
- $Re \geq 20,000$  :  $\pm 1.5\%$  of reading (gas and steam)
  - $10,000 < Re < 20,000$  :  $\pm 2.5\%$  of reading (gas and steam)

\* These values are display accuracy.

\* Add  $\pm 0.1\%$  of full scale to these values to obtain current output accuracy.

- Repeatability :  $\pm 0.1\%$

### Explosionproof Specifications

- JPN, ATEX, IECEx
  - \* For further details, refer to “Explosionproof Specifications” on pages 13 to 17.

### Measurable Flow Rate Range

- Measurable minimum and maximum flow velocities

[ $\rho$ : Fluid density (unit: kg/m<sup>3</sup>)]

	Min. velocity	Max. velocity
Liquid	The largest value among: • $0.5 \times (998/\rho)^{0.5}$ • Flow velocity when Re is 10,000 • 0.3 m/s	The smallest value among: • $7 \times (998/\rho)^{0.47}$ • 10 m/s
Gas, steam	The largest value among: • $6 \times (1.204/\rho)^{0.5}$ • Flow velocity when Re is 10,000 • 2 m/s (3 m/s for 15-mm meter size)	The smallest value among: • $7 \times (998/\rho)^{0.47}$ • 80 m/s (45 m/s for 15-mm meter size, 70 m/s for 25-mm meter size)

- Measurable flow rate range for water

[Temperature: 20°C]

Meter size	Flow rate range (m <sup>3</sup> /h)
15	(0.46) 0.91 to 5.04
25	(0.82) 1.36 to 11.3
40	(2.05) 2.15 to 28.4
50	3.54 to 49.2
80	7.75 to 107
100	13.4 to 185
150	30.2 to 419
200	56.7 to 787
250	90.5 to 1260
300	128 to 1772

Note: Values in parentheses are the minimum flow rates at an accuracy of  $\pm 2.0\%$ .

Other values are the minimum and the maximum flow rates at an accuracy of  $\pm 0.75\%$ .

● Measurable flow rate range for air  
 [Temperature: 0°C]

Meter size	Flow rate range (m³/h (nor))											
		0 MPa	0.1 MPa	0.2 MPa	0.3 MPa	0.4 MPa	0.5 MPa	0.6 MPa	0.8 MPa	1.0 MPa	1.5 MPa	2.0 MPa
15	Min.	(6.1) 12.1	(6.1) 12.1	(7.3) 12.1	(8.7) 12.1	(10.8) 12.1	13.0	15.1	19.5	23.8	34.7	45.6
	Max.	32.4	64.4	96.4	128	160	192	225	289	354	497	575
25	Min.	(9.5) 18.1	(13.3) 18.1	(16.3) 18.1	18.8	21.1	23.1	24.9	29.2	35.7	52.0	68.3
	Max.	113	225	337	450	562	664	721	824	917	1119	1295
40	Min.	(23.7) 28.6	33.4	40.8	47.1	52.7	57.7	62.4	73.0	89.3	131	172
	Max.	324	646	967	1289	1512	1665	1807	2066	2299	2807	3246
50	Min.	41.0	57.8	70.7	81.6	91.2	100	108	127	155	226	297
	Max.	562	1118	1675	2232	2618	2884	3129	3577	3980	4860	5620
80	Min.	89.7	127	155	179	200	219	237	277	339	494	650
	Max.	1232	2449	3669	4889	5734	6317	6855	7835	8718	10646	12312
100	Min.	154	218	266	307	344	376	406	476	582	848	1116
	Max.	2117	4209	6304	8401	9853	10854	11779	13463	14980	18293	21155
150	Min.	349	493	603	696	778	852	920	1078	1318	1921	2527
	Max.	4796	9536	14282	19033	22323	24590	26687	30500	33938	41443	47926
200	Min.	655	924	1130	1305	1459	1598	1726	2022	2473	3605	4742
	Max.	9000	17895	26801	35716	41891	46144	50079	57235	63685	77769	89935
250	Min.	1048	1478	1809	2088	2334	2557	2762	3235	3957	5768	7588
	Max.	14402	28636	42887	57154	67035	73841	80137	91589	101911	124448	143917
300	Min.	1474	2078	2543	2936	3282	3595	3884	4548	5563	8110	10669
	Max.	20250	40264	60302	80362	94254	103824	112677	128779	143292	174980	202355

Note: Values in parentheses are the minimum flow rates at an accuracy of ±2.0% (±2.5% when corrected by temperature and pressure).  
 Other values are the minimum and the maximum flow rates at an accuracy of ±1.0% (±1.5% when corrected by temperature and pressure).

**● Measurable flow rate range for saturated steam**

Meter size	Flow rate range (kg/h)										
		0.1 MPa	0.2 MPa	0.3 MPa	0.4 MPa	0.5 MPa	0.6 MPa	0.8 MPa	1.0 MPa	1.5 MPa	2.0 MPa
15	Min.	(5.9) 11.8	(6.2) 12.2	(7.1) 12.5	(7.8) 12.8	(8.5) 13.0	(9.2) 13.2	(10.3) 13.5	(12.3) 13.8	17.6	22.9
	Max.	36.7	53.6	70.2	86.6	102	118	150	182	261	341
25	Min.	(11.5) 17.7	(13.8) 18.3	(15.8) 18.8	(17.6) 19.1	19.1	20.6	23.2	25.5	30.5	34.8
	Max.	128	187	245	303	359	416	528	639	881	1014
40	Min.	28.7	34.6	39.6	44.0	47.9	51.5	58.1	63.9	76.5	87.3
	Max.	368	538	704	868	1031	1192	1513	1826	2210	2543
50	Min.	49.6	60.0	68.6	76.1	83.0	89.2	101	111	133	152
	Max.	638	932	1219	1503	1785	2064	2620	3161	3826	4403
80	Min.	109	132	151	167	182	196	220	243	290	331
	Max.	1399	2041	2671	3293	3910	4522	5739	6925	8382	9644
100	Min.	187	226	258	287	312	336	378	416	498	569
	Max.	2404	3507	4590	5659	6719	7771	9861	11899	14402	16571
150	Min.	423	511	585	649	707	761	857	943	1129	1288
	Max.	5446	7946	10399	12822	15222	17606	22340	26958	32628	37542
200	Min.	794	959	1097	1218	1327	1427	1607	1768	2117	2417
	Max.	10220	14912	19515	24061	28564	33038	41922	50589	61228	70450
250	Min.	1270	1534	1755	1948	2123	2283	2572	2830	3388	3867
	Max.	16335	23862	31229	38503	45710	52868	67085	80953	97978	112736
300	Min.	1786	2157	2467	2739	2985	3210	3616	3978	4763	5437
	Max.	22996	33552	43910	54137	64270	74336	94325	113825	137763	158512

Note: Values in parentheses are the minimum flow rates at an accuracy of  $\pm 2.0\%$  ( $\pm 2.5\%$  when corrected by temperature and pressure).

Other values are the minimum and the maximum flow rates at an accuracy of  $\pm 1.0\%$  ( $\pm 1.5\%$  when corrected by temperature and pressure).

## PRESSURE LOSS

$$\Delta P = C \times \rho \times 10^{-4}$$

$\Delta P$  : Pressure loss [kPa]  
 $\rho$  : Density [kg/m<sup>3</sup>]

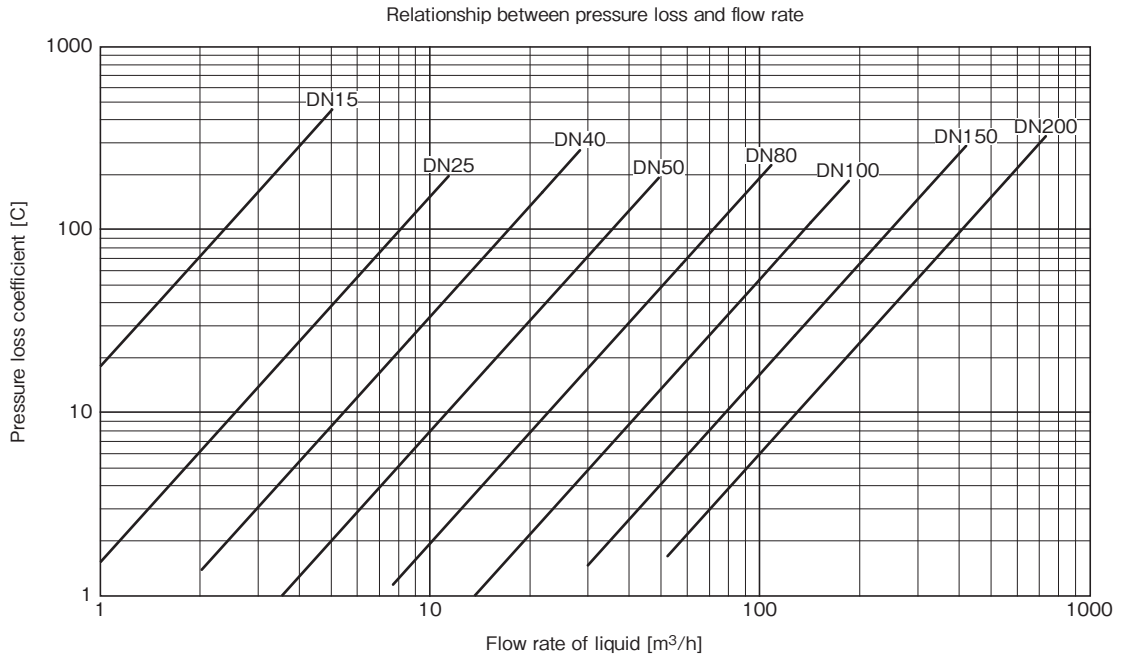

$$\Delta P = C \times \rho \times 10^{-4}$$

$\Delta P$  : Pressure loss [kPa]  
 $\rho$  : Density [kg/m<sup>3</sup>]

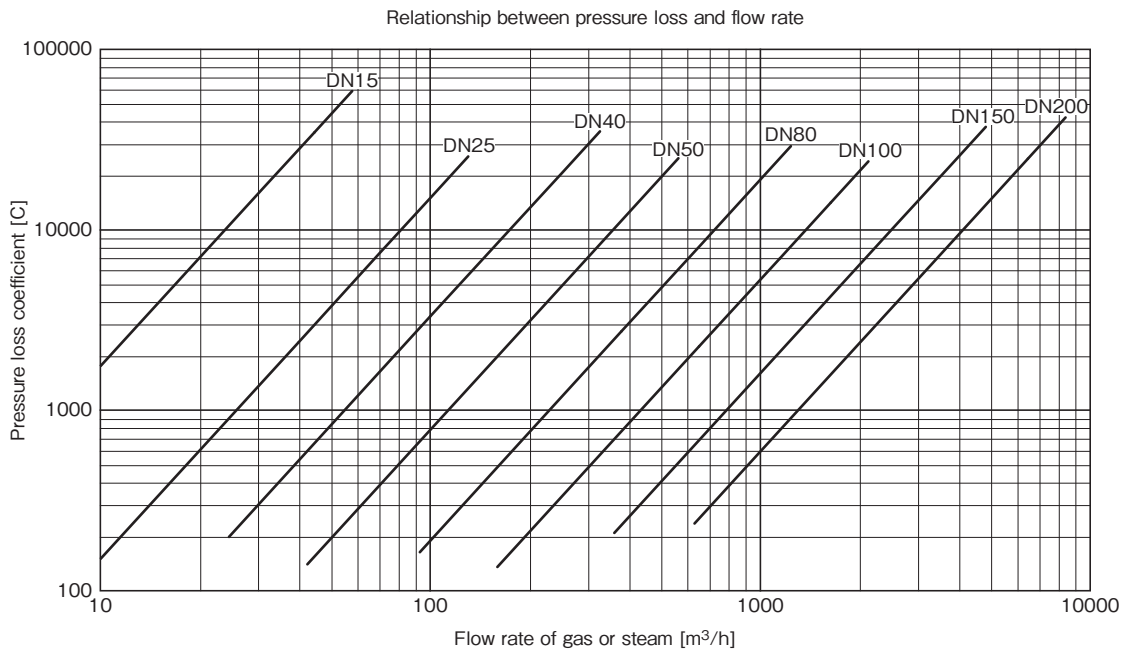

Note: The pressure loss values shown above are when the meter size is equal to the connection size.  
 If you need to know the pressure loss of reduced types (the meter size is smaller than the connection size), please contact us or your local representative.

**DIMENSIONS**

**Compact version (VFM4200C)**

Flange Type

- Without pressure sensor

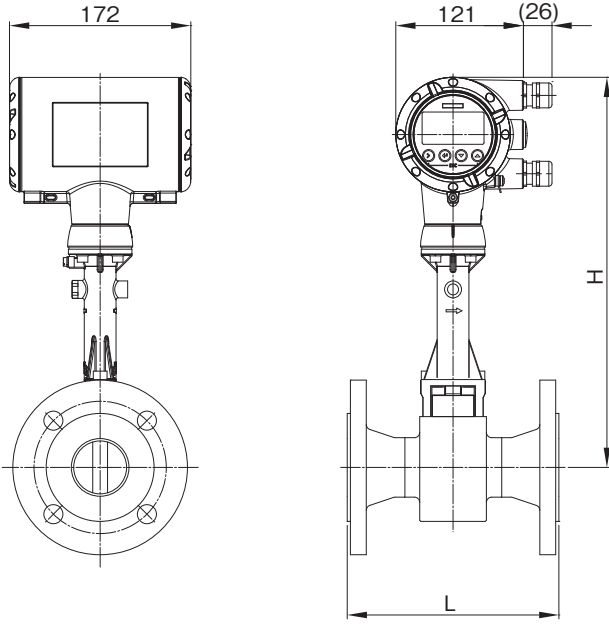

- With pressure sensor

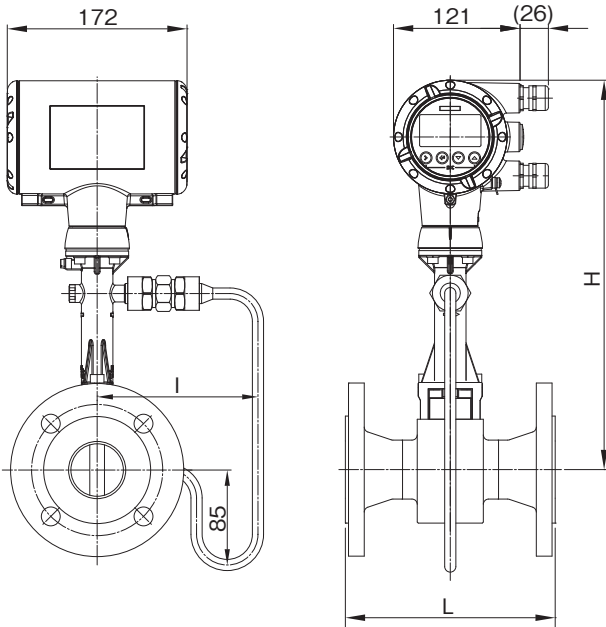

Wafer Type

- Without pressure sensor

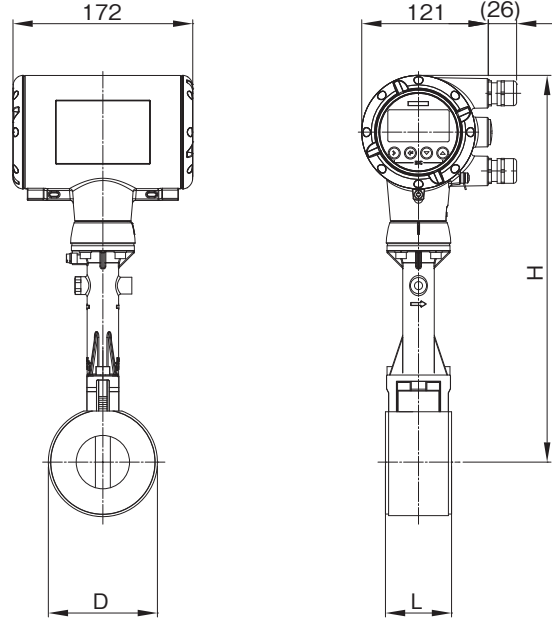

- With pressure sensor

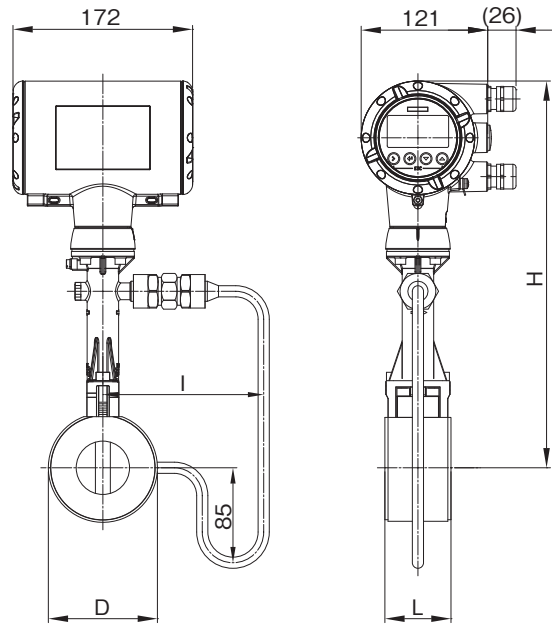

Connection size (mm)	Dimensions (mm)			Weight (Approx. kg) *1	
	L	H	I	Without pressure sensor	With pressure sensor
15	200	359	170	5	6
25	200	359	170	7	7
40	200	363	170	9	9
50	200	369	170	11	12
80	200	381	170	20	21
100	250	397	172	24	24
150	300	417	192	37	37
200	300	442	203	50	51
250	380	469	230	75	76
300	450	493	255	107	107

Connection size (mm)	Dimensions (mm)				Weight (Approx. kg)	
	L	H	D	I	Without pressure sensor	With pressure sensor
15	65	359	45	170	4	5
25	65	359	65	170	5	5
40	65	363	82	170	5	6
50	65	369	102	170	6	7
80	65	381	135	170	9	9
100	65	397	158	172	10	11

\*1: Weight of JIS10K flange type

**Remote version sensor (VFS4000)**

**Flange Type**

- Without pressure sensor

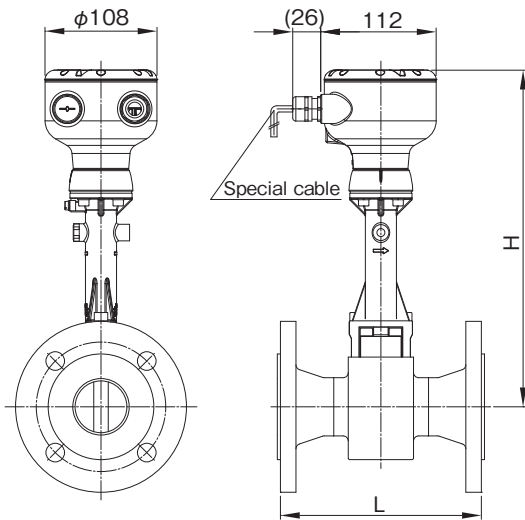

**Wafer Type**

- Without pressure sensor

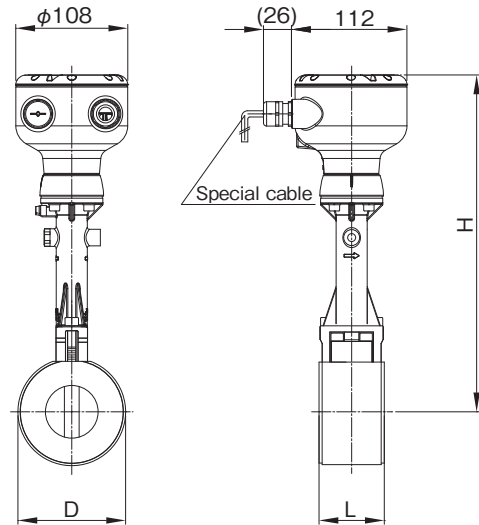

- With pressure sensor

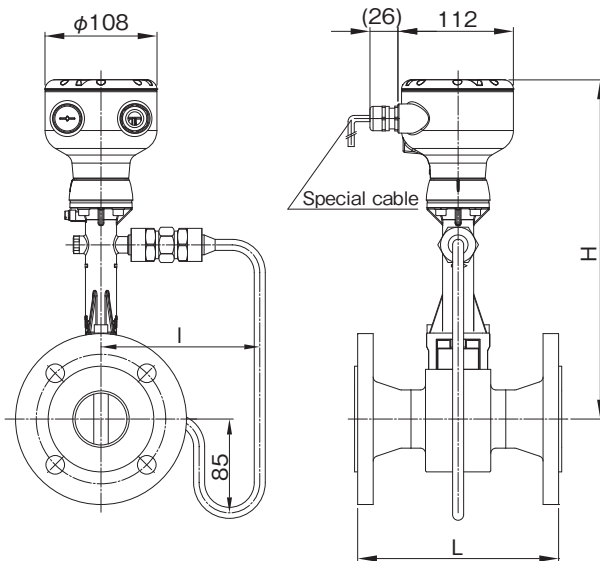

- With pressure sensor

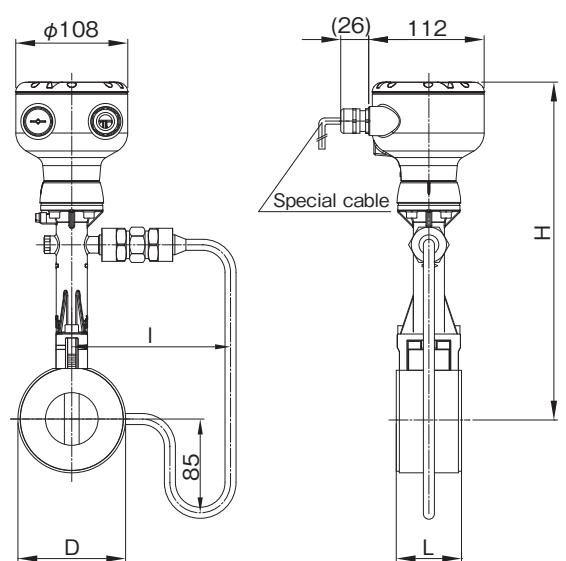

Connection size (mm)	Dimensions (mm)			Weight (Approx. kg) *1	
	L	H	I	Without pressure sensor	With pressure sensor
15	200	316	144	4	5
25	200	316	144	6	6
40	200	319	144	8	8
50	200	325	144	10	11
80	200	337	154	19	20
100	250	354	164	23	23
150	300	373	174	36	36
200	300	399	194	49	50
250	380	426	224	74	75
300	450	450	224	106	106

Connection size (mm)	Dimensions (mm)				Weight (Approx. kg) *1	
	L	H	D	I	Without pressure sensor	With pressure sensor
15	100	316	45	144	3	4
25	100	316	65	144	4	4
40	100	319	82	144	4	5
50	100	325	102	144	5	6
80	100	337	135	154	8	8
100	100	354	158	164	9	10

\*1: Weight of JIS10K flange type

Remote version converter (VFC200)

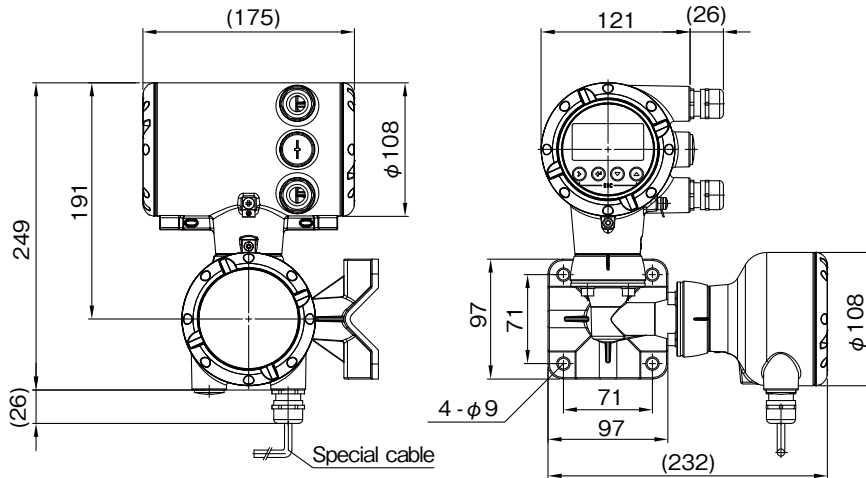

WIRING FOR REMOTE VERSION

<VFS4000 / Sensor>

<VFC200 / Sensor>

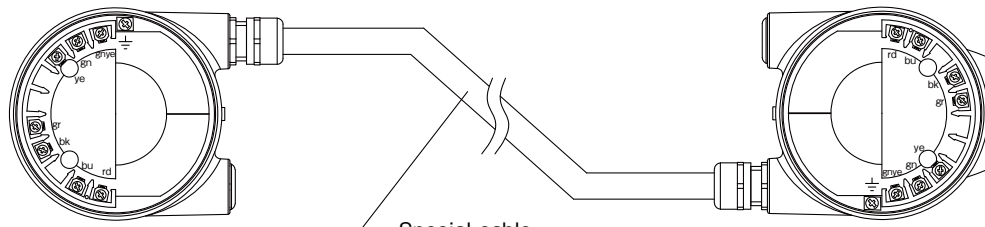

Shielding	⏏
Green/Yellow	gn ye
Green	gn
Yellow	ye
Grey	gr
Black	bk
Blue	bu
Red	rd

rd	Red
bu	Blue
bk	Black
gr	Grey
ye	Yellow
gn	Green
gn ye	Green/Yellow
⏏	Shielding



**MOUNTING DIRECTION OF CONVERTER AND DISPLAY (For compact version)**

● Without pressure sensor

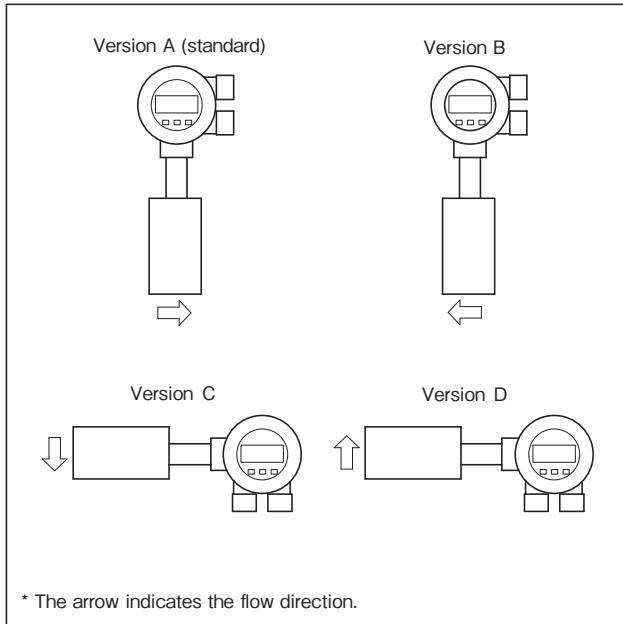

● With pressure sensor

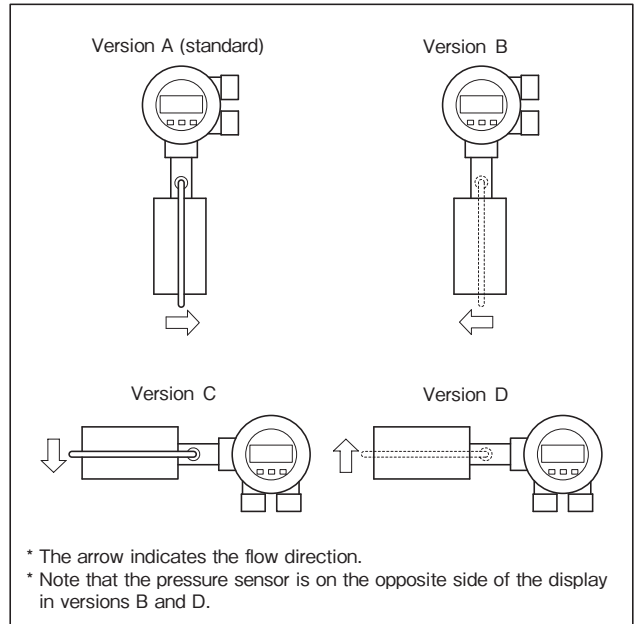

**WIRING**

● Power supply and current output

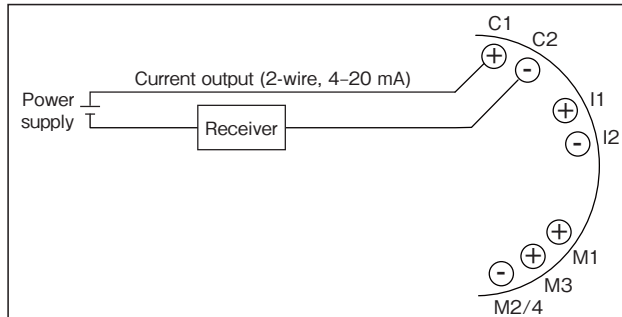

● Pulse output, frequency output, status output, or alarm output

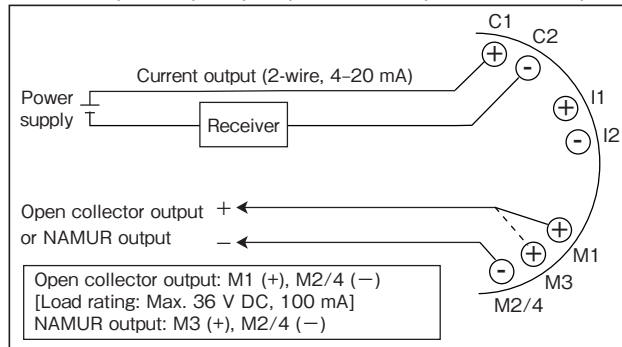

● When used as an intrinsically safe apparatus

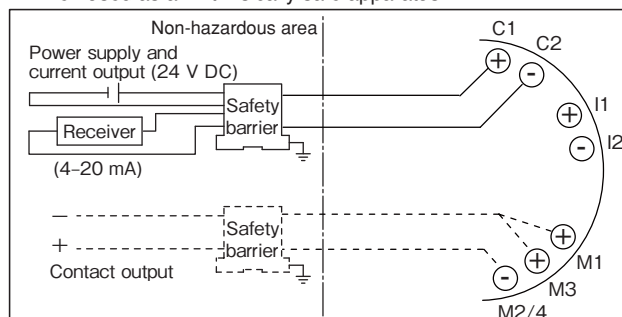

**STANDARD ACCESSORIES**

- Centering ring: 2 (only for wafer type)
- Magnet for setting data: 1
- Tool for removing the converter cover
- Tool for dismantling the display
- Setting data sheet: 1
- Instruction manual: 1

**OPTIONS**

- G1/2 watertight glands for cable entry: 1 set [symbol: WG]
  - No presetting of converter data (parameters) [symbol: NS]
- The flowmeter is delivered with the standard setting.  
Please set a flow rate range and other data necessary for operation.

**ORDERING INSTRUCTIONS**

1. Model and specification code  
Example:  
Model: VFM4200  
Spec code: VG164A2MM20001012010000000000
  2. Full-scale flow rate (unnecessary when the option NS is specified)
  3. Mounting direction of the converter and the display (version A, B, C, or D: Refer to the top of this page.)
  4. Options (Specify if necessary.)  
Specify the symbol with reference to [OPTIONS].
  5. Name, temperature, pressure, density, and viscosity of measured fluid
- Install safety barriers when the VFM4200 is used as an intrinsically safe apparatus.
  - Observe the requirements of the safety barrier.
  - When an isolation barrier is used, ensure that the power supply meets the requirements of the barrier.

MODEL CODE

Model: VFM4200 (flange type)

Specification code VG164	A					1	1	10000000000	Description	Standard
Fixed code	A								Always 1	○
Connection size	2								15 mm / 1/2"	○
	4								25 mm / 1"	○
	6								40 mm / 1-1/2"	○
	7								50 mm / 2"	○
	A								80 mm / 3"	○
	B								100 mm / 4"	○
	D								150 mm / 6"	○
	E								200 mm / 8"	○
Flange	F								250 mm / 10"	○
	G								300 mm / 12"	○
	A								ASME class 150	
	B								ASME class 300	
	D								ASME class 600	
Type	M								JIS 10K	○
	N								JIS 20K	○
Meter size	2								ASME flange	
	4								JIS flange	○
	6									
	7								15 mm / 1/2"	○
	A								25 mm / 1"	○
	B								40 mm / 1-1/2"	○
	D								50 mm / 2"	○
	E								80 mm / 3"	○
Pressure sensor	F								100 mm / 4"	○
	G								150 mm / 6"	○
	0								200 mm / 8"	○
	1								250 mm / 10"	○
	2								300 mm / 12"	○
	3								None	○
	4								Pressure sensor Max. 0.1 MPa	
	5								Pressure sensor Max. 0.2 MPa	
	6								Pressure sensor Max. 0.4 MPa	
	7								Pressure sensor Max. 0.6 MPa	
	8								Pressure sensor Max. 1 MPa	
	A								Pressure sensor Max. 1.6 MPa	
	B								Pressure sensor Max. 2.5 MPa	
	Gasket for Pressure sensor	C								Pressure sensor Max. 4 MPa
D									Pressure sensor Max. 6 MPa	
Explosionproof specifications	E								Pressure sensor with valve Max. 0.1 MPa	
	F								Pressure sensor with valve Max. 0.2 MPa	
	G								Pressure sensor with valve Max. 0.4 MPa	
	H								Pressure sensor with valve Max. 0.6 MPa	
	K								Pressure sensor with valve Max. 1 MPa	
	L								Pressure sensor with valve Max. 1.6 MPa	
	Y								Pressure sensor with valve Max. 2.5 MPa	
Housing material	M								Pressure sensor with valve Max. 4 MPa	
	N								Pressure sensor with valve Max. 6 MPa	
Type	1								Pressure sensor with valve Max. 10 MPa	
	0								Pressure sensor with valve Max. 0.1 MPa	
	1								Pressure sensor with valve Max. 0.2 MPa	
	2								Pressure sensor with valve Max. 0.4 MPa	
	3								Pressure sensor with valve Max. 0.6 MPa	
	4								Pressure sensor with valve Max. 1 MPa	
	5								Pressure sensor with valve Max. 1.6 MPa	
	6								Pressure sensor with valve Max. 2.5 MPa	
	7								Pressure sensor with valve Max. 4 MPa	
Display	8								Pressure sensor with valve Max. 6 MPa	
	K								Pressure sensor with valve Max. 10 MPa	
	N								Pressure sensor with valve Max. 10 MPa	
Cable entry	0								Standard (non-ex)	○
	1								ATEX (intrinsically safe)	
	2								ATEX (flameproof)	
	3								ATEX (dustproof)	
Version	4								ATEX (dustproof)	
	5								IECEX (intrinsically safe)	
	6								IECEX (flameproof)	
	7								IECEX (dustproof)	
Fixed code	8								IECEX (dustproof)	
	2								JPN Ex (flameproof)	
Special specification	0								Aluminum alloy	○
	1								Compact type	○
	2								Remote type / Cable length 5 m	
	Blank							Remote type / Cable length 10 m		
	/ Z							Remote type / Cable length 15 m		
								Remote type / Cable length 20 m		
								Remote type / Cable length 25 m		
								Remote type / Cable length 30 m		
								Remote type / Cable length 35 m		
								Remote type / Cable length 40 m		
								Remote type / Cable length 45 m		
								Remote type / Cable length 50 m		
								LCD	○	
								2 x M20 (with watertight cable gland)	○	
								2 x M20 (with metal cable gland / only for flameproof type)		
								2 x 1/2" NPT female adapter		
								2 x G1/2 female adapter		
								For Gas and Liquid without correction.	○	
								For Saturated steam with temperature correction.		
								For Gas and Superheated steam with temperature and pressure correction. *4		
								Always 10000000000	○	
								Blank Without	○	
								/ Z With special request *5	○	

\*1 JIS20K flanges are used as standard in common with JIS10K flanges for both connection sizes between 15 mm and 40 mm. \*2 Fluorocarbon rubber \*3 Perfluoroelastomer\*4 Selectable if with pressure sensor. \*5 Special requirements not included in the above coding system should be designated by adding "/Z" at the end of the code. Please describe the content separately.

Model: VFM4200 (wafer type)

Specification code VG164	A		0			1	1		10000000000	Description	Standard
Fixed code	A									Always 1	○
Connection size	2									15 mm / 1/2"	○
	4									25 mm / 1"	○
	6									40 mm / 1-1/2"	○
	7									50 mm / 2"	○
	A									80 mm / 3"	○
	B									100 mm / 4"	○
Flange	A									ASME class 150	
	B									ASME class 300	
	D									ASME class 600	
	M									JIS 10K	○
	N									JIS 20K	
Type			0							Wafer type	○
Meter size	2									15 mm / 1/2"	○
	4									25 mm / 1"	○
	6									40 mm / 1-1/2"	○
	7									50 mm / 2"	○
	A									80 mm / 3"	○
	B									100 mm / 4"	○
Pressure sensor	0									None	○
	1									Pressure sensor Max. 0.1 MPa	
	2									Pressure sensor Max. 0.2 MPa	
	3									Pressure sensor Max. 0.4 MPa	
	4									Pressure sensor Max. 0.6 MPa	
	5									Pressure sensor Max. 1 MPa	
	6									Pressure sensor Max. 1.6 MPa	
	7									Pressure sensor Max. 2.5 MPa	
	8									Pressure sensor Max. 4 MPa	
	A									Pressure sensor Max. 6 MPa	
	B									Pressure sensor Max. 10 MPa	
	C									Pressure sensor with valve Max. 0.1 MPa	
	D									Pressure sensor with valve Max. 0.2 MPa	
	E									Pressure sensor with valve Max. 0.4 MPa	
F									Pressure sensor with valve Max. 0.6 MPa		
G									Pressure sensor with valve Max. 1 MPa		
H									Pressure sensor with valve Max. 1.6 MPa		
K									Pressure sensor with valve Max. 2.5 MPa		
L									Pressure sensor with valve Max. 4 MPa		
M									Pressure sensor with valve Max. 6 MPa		
N									Pressure sensor with valve Max. 10 MPa		
Gasket for Pressure sensor	0									None	○
	1									FPM *1	○
	2									FFKM *2	
Explosionproof specifications	0									Standard (non-ex)	○
	1									ATEX (intrinsically safe)	
	2									ATEX (flameproof)	
	4									ATEX (dustproof)	
	5									IECEX (intrinsically safe)	
	6									IECEX (flameproof)	
	8									IECEX (dustproof)	
	Y									JPN Ex (flameproof)	
Housing material							1			Aluminum alloy	○
Type	0									Compact type	○
	1									Remote type / Cable length 5 m	
	2									Remote type / Cable length 10 m	
	3									Remote type / Cable length 15 m	
	4									Remote type / Cable length 20 m	
	5									Remote type / Cable length 25 m	
	6									Remote type / Cable length 30 m	
	7									Remote type / Cable length 35 m	
	8									Remote type / Cable length 40 m	
	A									Remote type / Cable length 45 m	
B									Remote type / Cable length 50 m		
Display								1		LCD	○
Cable entry	2									2 × M20 (with watertight cable gland)	○
	8									2 × M20 (with metal cable gland / only for flameproof type)	
	K									2 × 1/2" NPT female adapter	
	N									2 × G1/2 female adapter	
Version	0									For Gas and Liquid without correction. For Saturated steam with temperature correction.	○
	2									For Gas and Superheated steam with temperature and pressure correction. *3	
Fixed code								10000000000		Always 10000000000	○
Special specification									Blank	Without	○
									/ Z	With special request *4	

\*1 Fluorocarbon rubber

\*2 Perfluoroelastomer

\*3 Selectable if with pressure sensor.

\*4 Special requirements not included in the above coding system should be designated by adding "/Z" at the end of the code. Please describe the content separately.

**REQUIRED LENGTH OF STRAIGHT RUN**

<Upstream>

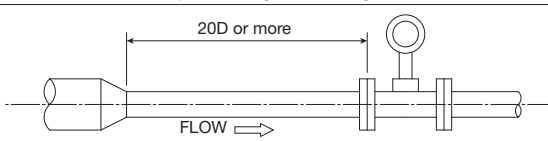
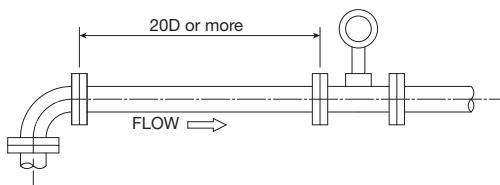
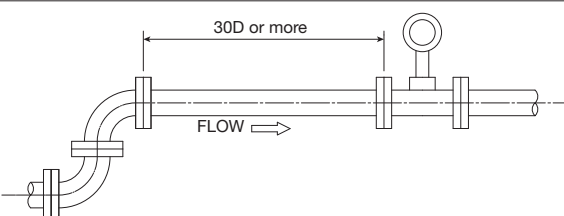
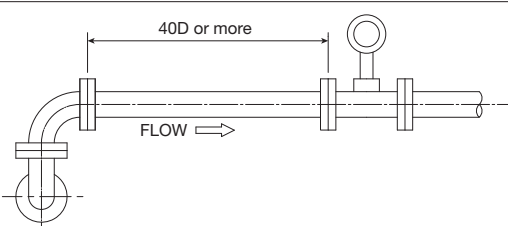
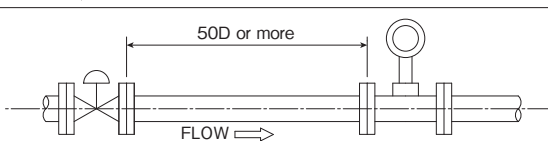
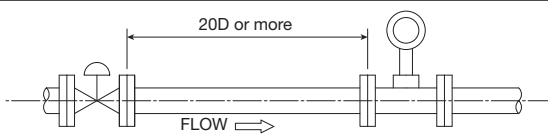
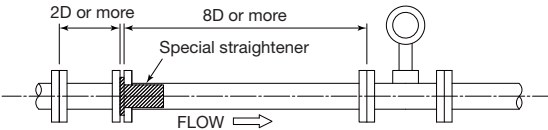
Arrangement	Required length of straight run
One reducer	
One elbow	
Two elbows in the same plane	
Two elbows in different planes	
Control valve	
Fully-opened gate valve	
In case of using a special straightener (Please contact us or your local representative about a special straightener)	

Note: D means the connection size.

<Downstream>

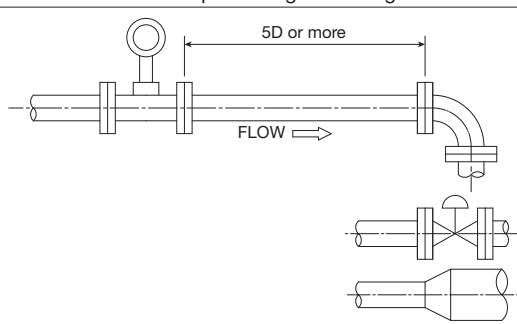
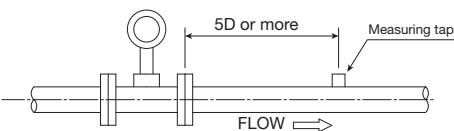
Arrangement	Required length of straight run
One elbow, control valve, or reducer	
Measuring tap	

Note: D means the connection size.

## Explosionproof Specifications

- JPN Ex (flameproof)
- Certificate No. : CML 20JPN1032X
- Model : VFM4200C-JEx, VFS4000-JEx, VFC200-JEx
- Type of protection and class : VFM4200C-JEx; Ex db ia IIC T6...T2 Gb  
VFS4000-JEx; Ex ia IIC T6...T2 Gb  
VFC200-JEx; Ex db [ia] IIC T6 Gb
- Ambient temperature : -40°C to a value in the table below
- Fluid temperature : -40°C to a value in the table below

<When the converter or the connection box is above the sensor>

[°C]	Temperature class											
	T6		T5		T4		T3			T2		
Ambient temperature	60	65	60	65	60	65	40	60	65	40	60	65
Meter size	Max. fluid temperature											
15 mm, 25 mm	80	65	100	100	135	135	200	200	165	240	200	165
40 mm, 50 mm	80	65	100	100	135	135	200	175	150	240	175	150
80 mm, 100 mm	80	65	100	100	135	130	200	150	130	235	150	130
150 mm-300 mm	75	65	100	100	135	135	200	185	155	240	185	155

<When the converter or the connection box is at the same level as or below the sensor>

[°C]	Temperature class											
	T6		T5		T4		T3			T2		
Ambient temperature	60	65	60	65	60	65	40	60	65	40	60	65
Meter size	Max. fluid temperature											
15 mm, 25 mm	85	65	100	100	135	135	200	200	200	240	240	240
40 mm, 50 mm	80	65	100	100	135	135	200	200	200	240	240	240
80 mm, 100 mm	85	65	100	100	135	135	200	200	200	240	240	240
150 mm-300 mm	80	65	100	100	135	135	200	200	200	240	240	240

Note) Use cable of at least 60°C rating for wiring.

Electrical ratings: [VFM4200C-JEx, VFC200-JEx] :

Power supply and current output (terminals C1 and C2)

Voltage = 12 to 32 V DC

Current = 4 to 20 mA

Contact output, open collector output (terminals M1 and M2/M4)

Voltage = 8 to 32 V DC

Current = 100 mA or lower

Contact output, NAMUR output (terminals M3 and M2/M4)

Voltage = 8 V DC

Current = 1 mA or 3 mA

Current input (terminals I1 and I2)

Voltage = 9 to 32 V DC

Current = 4 to 20 mA

## ● ATEX (intrinsically safe)

Certificate No. : KIWA 18ATEX0032X  
 Model : VFM4200C, VFS4000, VFC200  
 Type of protection and class : II 2 G Ex ia IIC T6...T2 Gb  
 Ambient temperature : -40°C to a value in the table below  
 Fluid temperature : -40°C to a value in the table below

&lt;When the converter or the connection box is above the sensor&gt;

[°C]	Temperature class								
	T6	T5	T4	T3			T2		
Ambient temperature	40	60	65	40	60	65	40	60	65
Meter size	Max. fluid temperature								
15 mm, 25 mm	85	65	135	200	200	185	240	210	185
40 mm, 50 mm	75	65	135	200	195	165	240	195	165
80 mm, 100 mm	70	65	135	200	165	145	240	165	145
150 mm to 300 mm	80	65	135	200	200	170	240	200	170

&lt;When the converter or the connection box is at the same level as or below the sensor&gt;

[°C]	Temperature class				
	T6	T5	T4	T3	T2
Ambient temperature	40	60	65	65	65
Meter size	Max. fluid temperature				
15 mm, 25 mm	85	90	135	200	240
40 mm, 50 mm	85	80	135	200	240
80 mm, 100 mm	85	75	135	200	240
150 mm to 300 mm	85	80	135	200	240

## Intrinsically safe circuit rating:

Power supply and current output (terminals C1 and C2)  
 Maximum voltage for intrinsically safe circuit (Ui) = 30 V  
 Maximum current for intrinsically safe circuit (Ii) = 130 mA  
 Maximum power for intrinsically safe circuit (Pi) = 1 W  
 Internal capacitance (Ci) = 10 nF  
 Internal inductance (Li): Negligibly small

## Contact output (terminals M1 and M2/M4 or M3 and M2/M4)

Maximum voltage for intrinsically safe circuit (Ui) = 30 V  
 Maximum current for intrinsically safe circuit (Ii) = 100 mA  
 Maximum power for intrinsically safe circuit (Pi) = 1 W  
 Internal capacitance (Ci) = 10 nF  
 Internal inductance (Li): Negligibly small

## Current input (terminals I1 and I2)

Maximum voltage for intrinsically safe circuit (Ui) = 30 V  
 Maximum current for intrinsically safe circuit (Ii) = 130 mA  
 Maximum power for intrinsically safe circuit (Pi) = 1 W  
 Internal capacitance (Ci) = 10 nF  
 Internal inductance (Li): Negligibly small

To enable this product to work as an intrinsically safe apparatus, safety barriers must be installed in the 2-wire loop in a non-hazardous area. A barrier is required for each of the terminals for power supply and current output; contact output; and current input, if these are used.

## Recommended barriers (optional)

- For power supply and current output: KFD2-STC4-Ex1 intrinsically safe isolation barrier (Pepperl+Fuchs)
- For contact output and current input: Z728 intrinsically safe Zener barrier (Pepperl+Fuchs)

● ATEX (flameproof/increased safety/dust proof)

Certificate No. : KIWA 18ATEX0034X

Model : VFM4200C, VFS4000, VFC200

Type of protection and class : VFM4200C ; II 2 G Ex db ia IIC T6...T2 Gb or II 2 G Ex db eb ia IIC T6...T2 Gb or II 2 D Ex tb ia IIIC T70°C...T240°C Db

VFS4000 ; II 2 G Ex ia IIC T6...T2 Gb or II 2 D Ex ia IIIC T70°C...T240°C Db

VFC200 ; II 2 G Ex db [ia] IIC T6 Gb or II 2 G Ex db eb [ia] IIC T6 Gb or II 2 D Ex tb [ia] IIIC T70°C Db

Ambient temperature : -40°C to a value in the table below

Fluid temperature : -40°C to a value in the table below

<When the converter or the connection box is above the sensor>

[°C]	Temperature class											
	T6		T5		T4		T3			T2		
Ambient temperature	60	65	60	65	60	65	40	60	65	40	60	65
Meter size	Max. fluid temperature											
15 mm, 25 mm	80	65	100	100	135	135 <sup>*</sup>	200	200 <sup>*</sup>	165 <sup>*</sup>	240	200 <sup>*</sup>	165 <sup>*</sup>
40 mm, 50 mm	80	65	100	100	135	135 <sup>*</sup>	200	175 <sup>*</sup>	150 <sup>*</sup>	240	175 <sup>*</sup>	150 <sup>*</sup>
80 mm, 100 mm	80	65	100	100 <sup>*</sup>	135 <sup>*</sup>	130 <sup>*</sup>	200	150 <sup>*</sup>	130 <sup>*</sup>	235 <sup>*</sup>	150 <sup>*</sup>	130 <sup>*</sup>
150 mm to 300 mm	75	65	100	100	135	135 <sup>*</sup>	200	185 <sup>*</sup>	155 <sup>*</sup>	240	185 <sup>*</sup>	155 <sup>*</sup>

<When the converter or the connection box is at the same level as or below the sensor>

[°C]	Temperature class											
	T6		T5		T4		T3			T2		
Ambient temperature	60	65	60	65	60	65	40	60	65	40	60	65
Meter size	Max. fluid temperature											
15 mm, 25 mm	85	65	100	100	135	135	200	200	200 <sup>*</sup>	240	240	240 <sup>*</sup>
40 mm, 50 mm	80	65	100	100	135	135	200	200	200 <sup>*</sup>	240	240	240 <sup>*</sup>
80 mm, 100 mm	85	65	100	100	135	135 <sup>*</sup>	200	200 <sup>*</sup>	200 <sup>*</sup>	240	240 <sup>*</sup>	240 <sup>*</sup>
150 mm to 300 mm	80	65	100	100	135	135	200	200	200 <sup>*</sup>	240	240	240 <sup>*</sup>

\* Use heat-resistant cables (at least 80°C rating) for wiring.

Electrical ratings:

Power supply and current output (terminals C1 and C2)

Voltage = 12 to 32 V DC

Current = 4 to 20 mA

Contact output, open collector output (terminals M1 and M2/M4)

Voltage = 8 to 32 V DC

Current = 100 mA or lower

Contact output, NAMUR output (terminals M3 and M2/M4)

Voltage = 8 V DC

Current = 1 mA or 3 mA

Current input (terminals I1 and I2)

Voltage = 9 to 32 V DC

Current = 0 to 20 mA

## • IECEx (intrinsically safe)

Certificate No. : IECEx KIWA 19.0023X  
 Model : VFM4200C, VFS4000, VFC200  
 Type of protection and class : Ex ia IIC T6...T2 Gb  
 Ambient temperature : -40°C to a value in the table below  
 Fluid temperature : -40°C to a value in the table below

&lt;When the converter or the connection box is above the sensor&gt;

[°C]	Temperature class								
	T6	T5	T4	T3			T2		
Ambient temperature	40	60	65	40	60	65	40	60	65
Meter size	Max. fluid temperature								
15 mm, 25 mm	85	65	135	200	200	185	240	210	185
40 mm, 50 mm	75	65	135	200	195	165	240	195	165
80 mm, 100 mm	70	65	135	200	165	145	240	165	145
150 mm-300 mm	80	65	135	200	200	170	240	200	170

&lt;When the converter or the connection box is at the same level as or below the sensor&gt;

[°C]	Temperature class				
	T6	T5	T4	T3	T2
Ambient temperature	40	60	65	65	65
Meter size	Max. fluid temperature				
15 mm, 25 mm	85	90	135	200	240
40 mm, 50 mm	85	80	135	200	240
80 mm, 100 mm	85	75	135	200	240
150 mm-300 mm	85	80	135	200	240

Intrinsically safe circuit rating [VFM4200C, VFC200]:

Power supply and current output (terminals C1 and C2)  
 Maximum voltage for intrinsically safe circuit (Ui) = 30 V  
 Maximum current for intrinsically safe circuit (Ii) = 130 mA  
 Maximum power for intrinsically safe circuit (Pi) = 1 W  
 Internal capacitance (Ci) = 10 nF  
 Internal inductance (Li): Negligibly small

Contact output (terminals M1 and M2/M4 or M3 and M2/M4)  
 Maximum voltage for intrinsically safe circuit (Ui) = 30 V  
 Maximum current for intrinsically safe circuit (Ii) = 100 mA  
 Maximum power for intrinsically safe circuit (Pi) = 1 W  
 Internal capacitance (Ci) = 10 nF  
 Internal inductance (Li): Negligibly small

Current input (terminals I1 and I2)  
 Maximum voltage for intrinsically safe circuit (Ui) = 30 V  
 Maximum current for intrinsically safe circuit (Ii) = 130 mA  
 Maximum power for intrinsically safe circuit (Pi) = 1 W  
 Internal capacitance (Ci) = 10 nF  
 Internal inductance (Li): Negligibly small

To enable this product to work as an intrinsically safe apparatus, safety barriers must be installed in the 2-wire loop in a non-hazardous area. A barrier is required for each of the terminals for power supply and current output; contact output; and current input, if these are used.

Recommended barriers (optional)

- For power supply and current output: KFD2-STC4-Ex1 intrinsically safe isolation barrier (Pepperl+Fuchs)
- For contact output and current input: Z728 intrinsically safe Zener barrier (Pepperl+Fuchs)



- IECEx (flameproof/increased safety/dust proof)

Certificate No. : IECEx KIWA 19.0024X

Model : VFM4200C, VFS4000, VFC200

Type of protection and class : VFM4200C; Ex db ia IIC T6...T2 Gb or Ex db eb ia IIC T6...T2 Gb or Ex tb ia IIIC T70°C...T240°C Db  
VFS4000; Ex ia IIC T6...T2 Gb or Ex ia IIIC T70°C...T240°C Db

VFC200; Ex db [ia] IIC T6 Gb or Ex db eb [ia] IIC T6 Gb or Ex tb [ia] IIIC T70°C Db

Ambient temperature : -40°C to a value in the table below

Fluid temperature : -40°C to a value in the table below

<When the converter or the connection box is above the sensor>

[°C]	Temperature class											
	T6		T5		T4		T3			T2		
Ambient temperature	60	65	60	65	60	65	40	60	65	40	60	65
Meter size	Max. fluid temperature											
15 mm, 25 mm	80	65	100	100	135	135 <sup>*)</sup>	200	200 <sup>*)</sup>	165 <sup>*)</sup>	240	200 <sup>*)</sup>	165 <sup>*)</sup>
40 mm, 50 mm	80	65	100	100	135	135 <sup>*)</sup>	200	175 <sup>*)</sup>	150 <sup>*)</sup>	240	175 <sup>*)</sup>	150 <sup>*)</sup>
80 mm, 100 mm	80	65	100	100 <sup>*)</sup>	135 <sup>*)</sup>	130 <sup>*)</sup>	200	150 <sup>*)</sup>	130 <sup>*)</sup>	235 <sup>*)</sup>	150 <sup>*)</sup>	130 <sup>*)</sup>
150 mm-300 mm	75	65	100	100	135	135 <sup>*)</sup>	200	185 <sup>*)</sup>	155 <sup>*)</sup>	240	185 <sup>*)</sup>	155 <sup>*)</sup>

<When the converter or the connection box is at the same level as or below the sensor>

[°C]	Temperature class											
	T6		T5		T4		T3			T2		
Ambient temperature	60	65	60	65	60	65	40	60	65	40	60	65
Meter size	Max. fluid temperature											
15 mm, 25 mm	85	65	100	100	135	135	200	200	200 <sup>*)</sup>	240	240	240 <sup>*)</sup>
40 mm, 50 mm	80	65	100	100	135	135	200	200	200 <sup>*)</sup>	240	240	240 <sup>*)</sup>
80 mm, 100 mm	85	65	100	100	135	135 <sup>*)</sup>	200	200 <sup>*)</sup>	200 <sup>*)</sup>	240	240 <sup>*)</sup>	240 <sup>*)</sup>
150 mm-300 mm	80	65	100	100	135	135	200	200	200 <sup>*)</sup>	240	240	240 <sup>*)</sup>

\* Use heat-resistant cables (at least 80°C rating) for wiring.

Electrical ratings: [VFM4200C, VFC200] :

Power supply and current output (terminals C1 and C2)

Voltage = 12 to 32 V DC

Current = 4 to 20 mA

Contact output, open collector output (terminals M1 and M2/M4)

Voltage = 8 to 32 V DC

Current = 100 mA or lower

Contact output, NAMUR output (terminals M3 and M2/M4)

Voltage = 8 V DC

Current = 1 mA or 3 mA

Current input (terminals I1 and I2)

Voltage = 9 to 32 V DC

Current = 4 to 20 mA